

NA - GH4

Underwater Camera Housing
Instruction manual



Foreword

Thank you for your purchase of a NAUTICAM camera housing.

At NAUTICAM, we pride ourselves on the ability to recognise the requirements of professional as well as amateur underwater photographers and fulfill them through the innovative designs of our products. We strive to achieve a high level of user-friendliness by allowing stress-free installation and easy operation of all important functions of the camera.

Each housing is individually inspected and water pressure tested to ensure optimum quality.

Please read this manual carefully before using the housing, this will maximise its performance as well as its lifetime.

Warranty

1. All NAUTICAM Products are warranted against any material and manufacturing defects for one year from the date of purchase for consumer use.
2. NAUTICAM accepts no liability for any damage to and defects in the housing caused by improper use and/or poor maintenance; it is the responsibility of the owner to carefully follow the instructions in this manual.
3. NAUTICAM does not hold responsibility for damage, of any nature, to any equipment used with and/or placed within the housing.
4. NAUTICAM accepts no liability for any loss of captured images or the inability to capture images even if it is due to the malfunctioning or leakage of the housing.
5. This warranty only applies to products purchased from authorised NAUTICAM dealers and does not extend beyond the original retail purchaser.
6. Unauthorised modifications and/or repairs of the housing will automatically invalidate this warranty.
7. To return products for service, please contact our regional distributor, normally you would need to notify them by email first and ship them the product by registered mail, along with your contact details and a brief description of the defect.

Package Contents

1. NA-GH4 housing
2. Instruction manual
3. Spare silicone rubber housing o-ring
4. O-ring remover
5. CR2450 battery (for moisture alarm)
6. Lubricant
7. Set of Allen keys

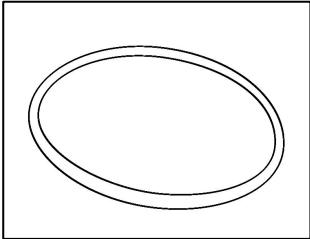

Spare silicone rubber o-ring

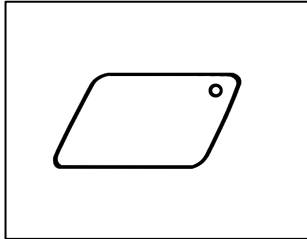

O-ring remover

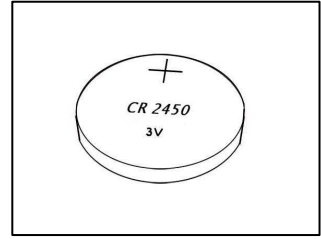

CR2450 battery



Lubricant

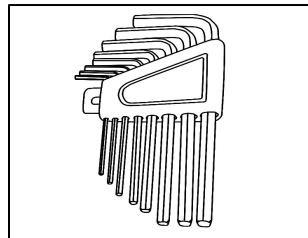

Set of Allen keys

Precautions

1. A water-tight test without the camera inside the housing is highly recommended when using the system for the first time and after the changing of port and O-ring(s).
2. Do not use lubricants from other brands with the silicone rubber O-ring on this housing, only use the lubricant provided by NAUTICAM.
3. Discontinue use immediately should you notice any leakage.
4. Store the housing in a robust, shock-proof container during transportation; avoid transporting with any equipment, such as a camera, inside the housing.
5. When travelling by air, do not close the housing if the port is installed, as this may lead to a pressure difference between the atmosphere and inside the housing.
6. Care must be taken when opening the housing, as pressure may build up inside the housing which increases the opening force.
7. Do not open the product in a wet or sandy environment. Protect the interior from moisture and debris in order to prevent malfunction or leakage.
8. Do not store the product in an environment of high humidity.
9. Do not leave the housing and the camera in direct sunlight for prolonged periods.
10. Keep out of reach of children, failure to do so could result in injury.
11. Defective products should be shipped to our distributors for service, unauthorized disassembling and/or modifications could result in malfunction or leakage.

Table of Contents

<i>Specifications</i>	6
<i>Identification of Parts</i>	7
<i>Preparation of the Housing</i>	11
<i>Opening and Locking the Housing</i>	14
<i>Installing the Camera</i>	15
<i>Mounting the Port</i>	17
<i>Care and Maintenance</i>	19
<i>Optional Accessories</i>	20

Specifications

Construction	Housing body:	Aluminium alloy
	Surface treatment:	Hard anodised
	Display window:	Abrasion resistant polycarbonate
Dimensions (with handles)	Width:	318mm
	Height:	171mm
	Depth:	121mm
Weight	Approx. 2.08kg (without camera)	
Buoyancy	Slightly negative	
Depth rating	100 metres	
Features	Moisture alarm:	Blinking LED and audible alarm
	TTL capability:	Optical fibre mount included for external strobes connection, utilising the camera's pop-up flash as trigger.
	Port mount:	Patented easy port installation system.
	Front dial:	Ergonomically placed below the shutter lever, it can be comfortably controlled by the middle or ring finger.
	AEL/AFL lever:	Easily reached by right thumb.
	Handles:	Tilted for better ergonomics.
	1/4"-20UNC top & bottom of housing:	Maximum versatility for tripod and shoulder support mounting options.

Identification of Parts

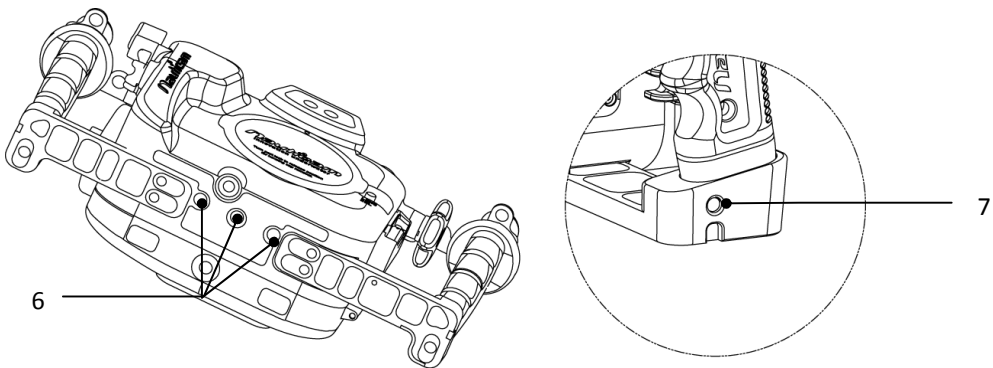
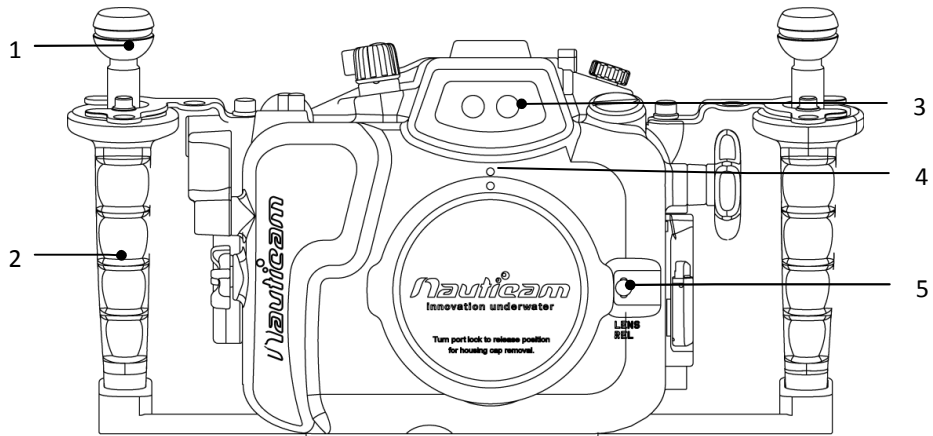

1	Ball joint x2	5	Lens release button
2	Adjustable handle x2	6	1/4"-20UNC tripod socket x 3*
3	Optical fibre mount	7	M5 threaded hole x2
4	Port alignment index		

* The maximum length of screws that can be used with the tripod sockets is 4mm

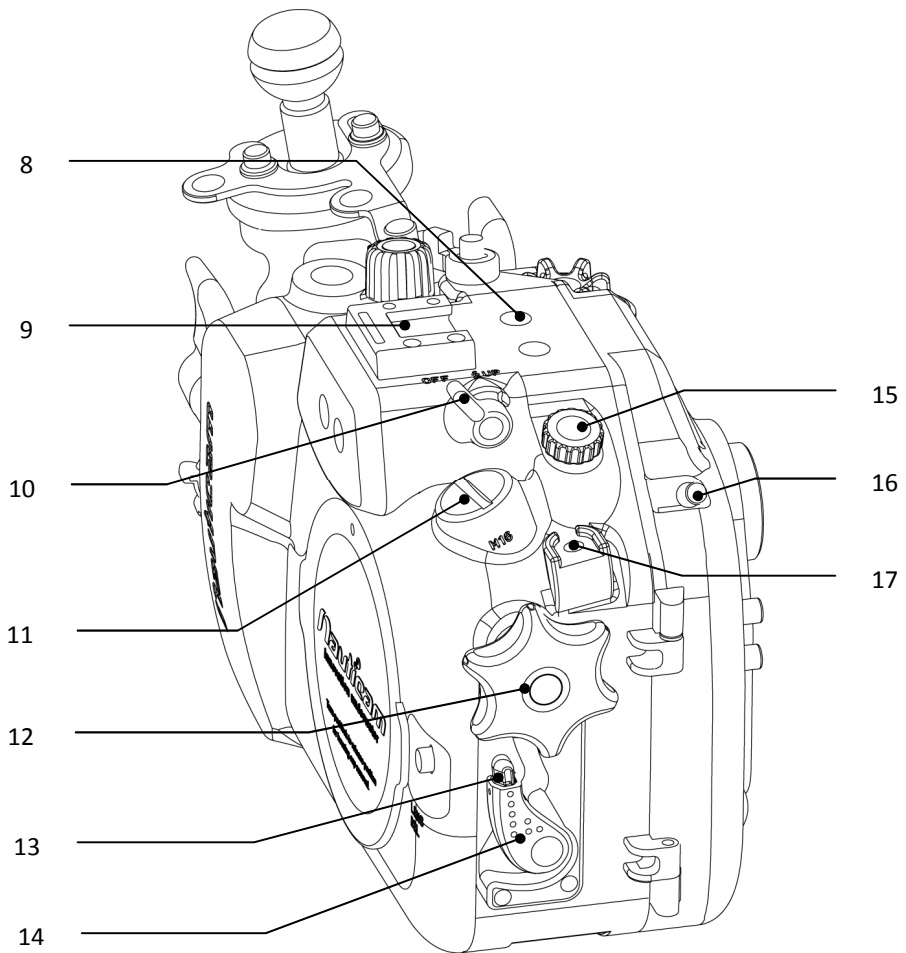

8	1/4"-20UNC threaded hole x2	13	Port release safety button
9	Accessory coldshoe	14	Port lock/release lever
10	Flash up/off lever	15	Drive mode dial
11	M16 accessory port	16	Flash open button
12	Zoom/Focus knob	17	M5 threaded hole

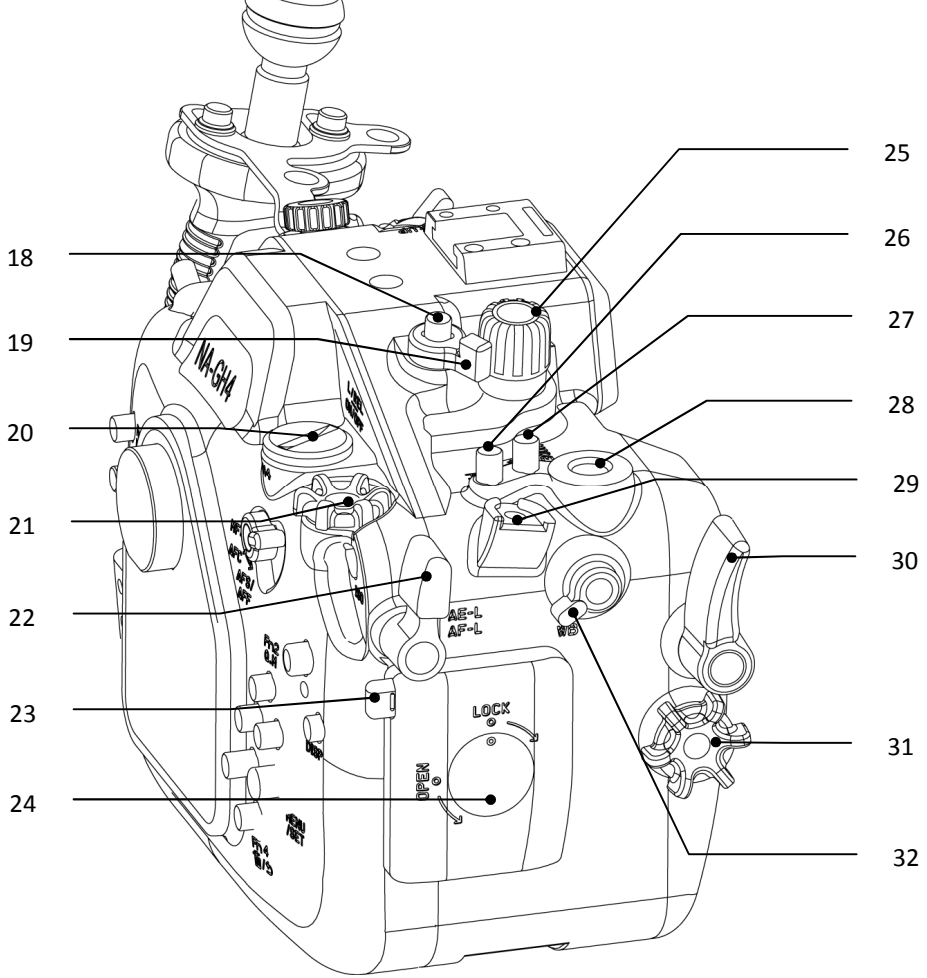

18	Mode dial lock button	26	Fn1 button
19	On/off lever	27	Exposure compensation button
20	M14 accessory port	28	M10 strobe mounting base
21	Rear dial	29	M5 threaded hole
22	AEL/AFL lever	30	Shutter release lever
23	Housing lock safety button	31	Front dial
24	Housing lock	32	WB lever
25	Mode dial		

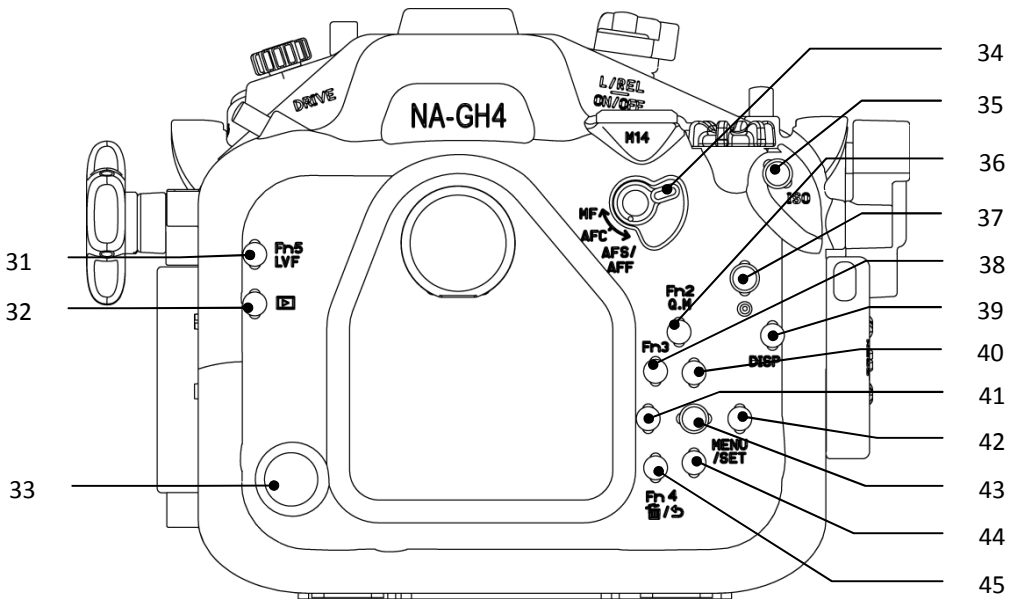

31	Fn5/LVF button	39	DISP button
32	Playback button	40	Up selection button
33	Moisture alarm window	41	Left selection button
34	Focus mode lever	42	Right selection button
35	ISO button	43	Menu/Set button
36	Fn2/Q.Menu button	44	Down selection button
37	Motion picture button	45	Fn4/Delete/Cancel button
38	Fn3/Auto focus mode button		

Preparation of the Housing

1. After verifying that the housing O-ring is in good condition, lightly coat it with the lubricant provided.
2. Make sure the O-ring groove located in the rear part of the housing is free from any foreign material; the groove can be cleaned with the aid of a microfiber cloth.
3. Place the O-ring into the groove.

4. Setting up the moisture alarm:

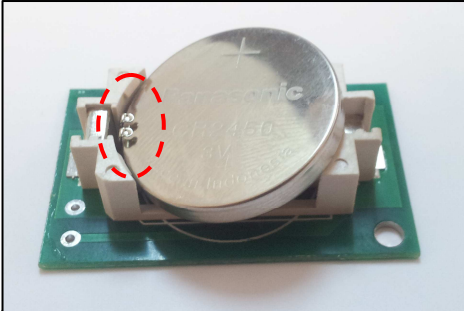

1. Install the CR2450 battery provided into the battery compartment inside the rear housing.

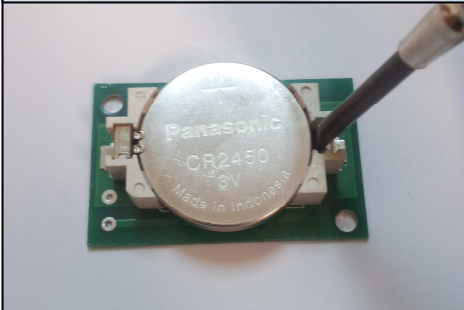

To remove the battery, use a small flat-head screwdriver to lift up the battery as shown.

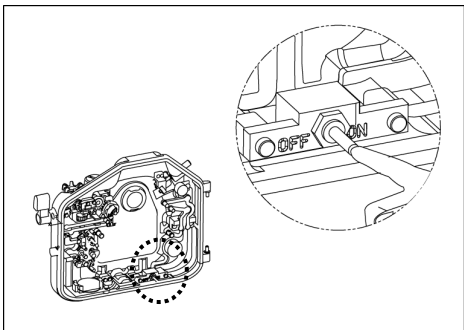

2. Switch the alarm on. The LED light will turn blue for five seconds indicating the battery is normal. Then it goes into flashing blue light standby mode.

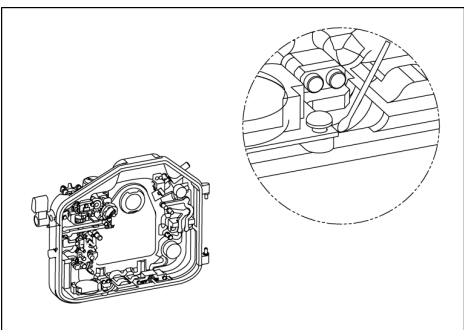

3. Test the alarm by contacting the two wires near the bottom of the housing with a damped cotton bud; the alarm should start giving out a repeating “beep” sound along with a flashing red light. The “beep” sound and the light should keep on going for 5 seconds after the removal of the damped cotton bud.

(Optional) Vacuum valve can be attached to the housing via one of the accessory port for conducting a vacuum seal test. Please refer to the manual of the vacuum valve for more details of the operation.

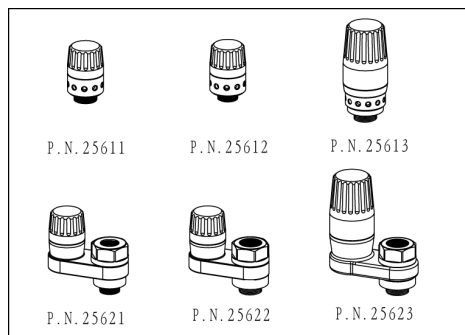

LED status identification:

On start up:

LED indicator	Status
Steady "Blue" light	Battery is normal, goes into flashing "Blue" light standby mode after 5 seconds.
"Blue" and "Red" lights alternating	Battery low. Replace battery as soon as possible. Goes into standby mode after 5 seconds.
Steady "Red" light	Battery empty, replace battery.

After start up:

LED indicator	Status
Flashing "Blue" light	Standby mode. The moisture alarm is active, and the system is ready for vacuum indication whenever a vacuum is detected.
Flashing "Red" light with audio sounds.	Moisture is detected.
Flashing "Yellow" light	Some vacuum is detected, target vacuum level is not reached.
Steady "Green" light	Target vacuum level is reached.
Rapidly flash "Yellow" light	Vacuum is dropping. (Will occur only after target vacuum level is reached)
Rapidly flashing "Red" light	Vacuum is totally lost. Circuit stalled until switched off. (Will occur only after target vacuum level is reached)

Opening and locking the housing

To open the housing:

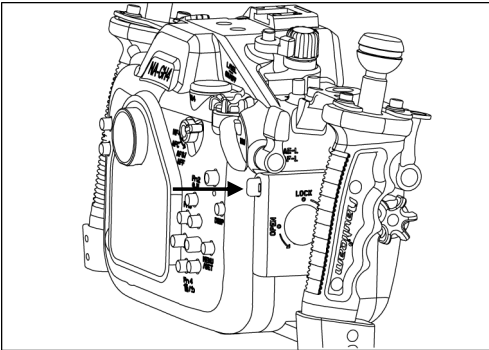

1. Press the housing lock safety button.

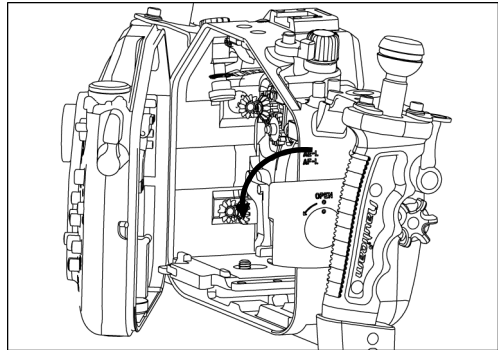

2. Turn the housing lock anti-clockwise for 270°, until the lock reaches the “Open” position as shown.

To lock the housing:

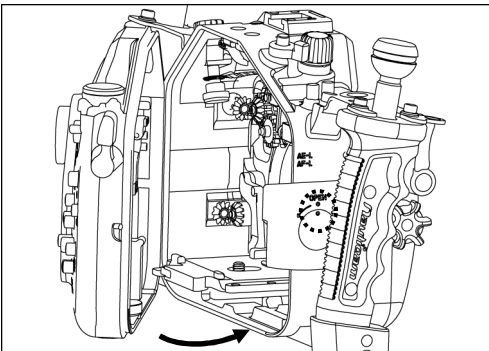

3. Close the housing while the housing lock is in the “Open” position.

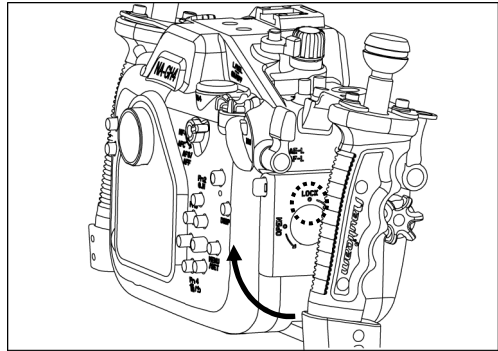

4. Turn the housing lock clockwise for 270°, until the lock reaches the “lock” position as shown. Confirm that the white indicator line on the safety button is visible.

Installing the Camera

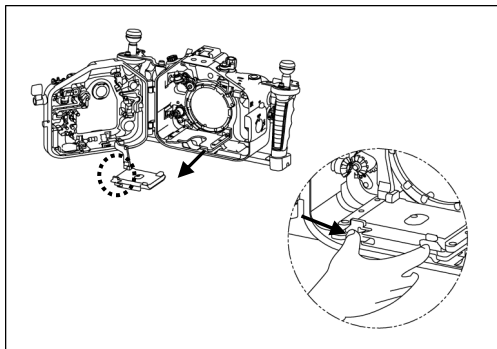

1. Disengage the red camera saddle lock by pressing it inwards. Remove the camera saddle from the housing by sliding it outwards

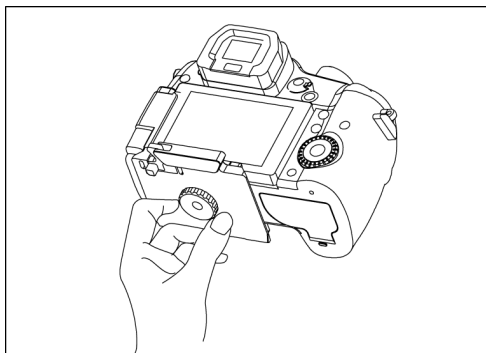

2. Tilt the LCD monitor of the camera upwards, then attach the saddle to the camera by tightening the screw to the tripod socket of the camera.

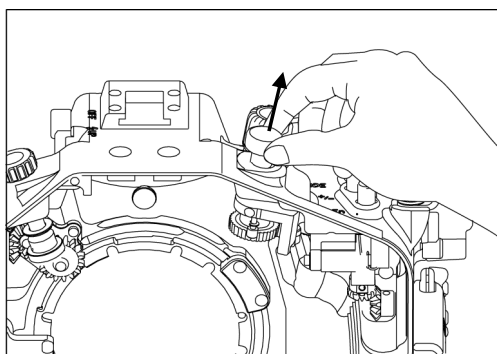

3. Lift the ON/OFF lever upwards.

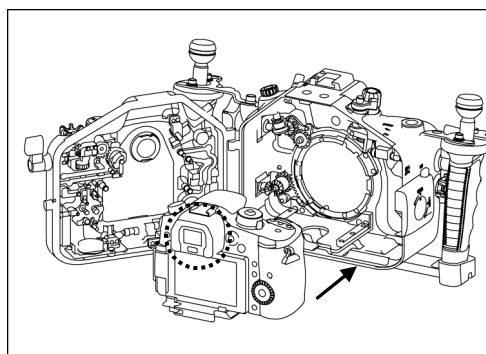

4. Please make sure the eyepiece cup is not attached to the camera. Install the camera by sliding the attached saddle along the rail in the housing until it cannot go in any further.

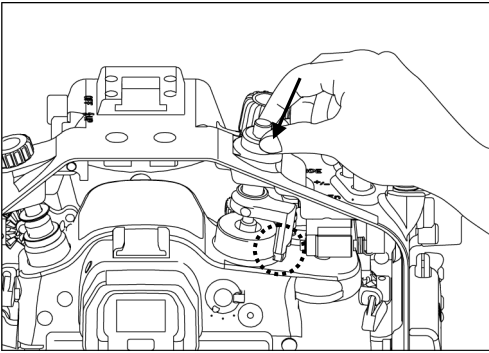

5. Gently push the ON/OFF lever downwards ensuring the actuator correctly engages with the ON/OFF lever of the camera.

6. For removal of the camera from the housing, reverse the above procedures.

Mounting the Port

Please refer to the NAUTICAM system port chart for a range of compatible ports.

1. Remove the O-ring from the port, inspect for any damage and lightly coat it with the provided lubricant before placing it back into its groove.
2. Verify that the port opening of the housing is clean and free from foreign material.

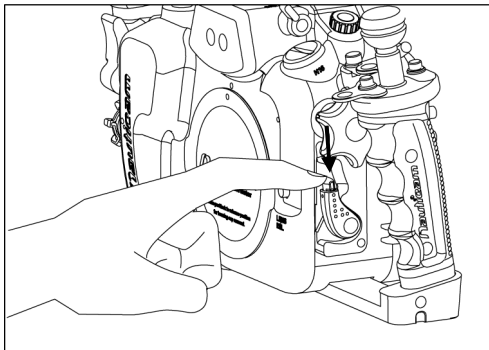

3. Push the safety button of the port locking lever downwards.

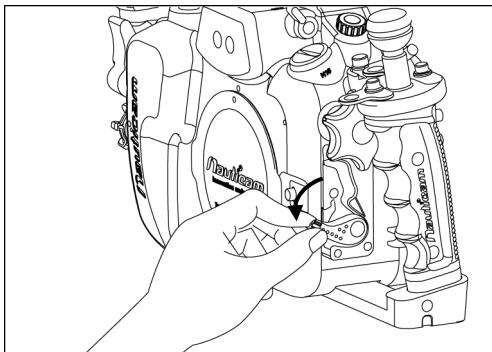

4. Turn the port locking lever to the release position as shown.

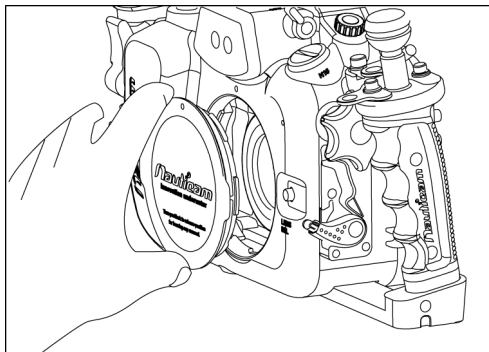

5. Lift housing cap.

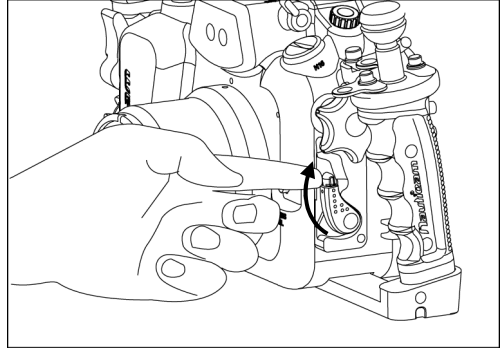
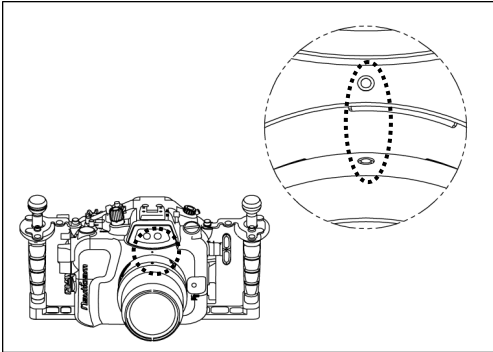

6. Align the Port mounting indices of the port and the housing.
7. Gently push the port into the port opening of the housing, until it cannot go in any further.
8. Lock the port into place by turning the port locking lever to the inward position. To ensure that the port is securely mounted, confirm that the green line on the safety button of the port locking lever is visible.
9. To remove the port from the housing, simply turn the port locking lever to the outward position and gently pull it out.

Care and Maintenance

1. Soak the housing system in fresh water after each salt water use, during which all control buttons/knobs should be operated a few times to avoid the accumulation of salt residue; wipe the housing with a towel before opening.
2. After each day of diving, it is advisable to have the main O-ring in the rear part of the housing removed from its groove with the O-ring remover and inspected for damage. Also check that the O-ring retains its original circular shape; never stretch the O-ring excessively or remove it with a sharp object. The O-ring groove should be cleaned to ensure it is free from any salt deposit or foreign material; lightly coat the O-ring with the provided lubricant before reinstalling it in the groove. A damaged O-ring should be discarded immediately and replaced only with one that is provided by NAUTICAM.
3. Replace the main O-ring annually.
4. It is recommended that you ship the housing to our distributor for a complete overhaul every year or after every 200 dives.

Optional Accessories

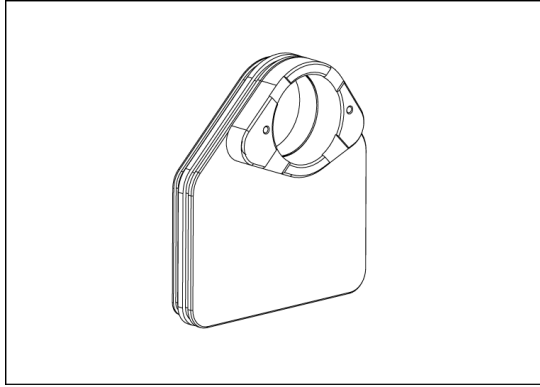

P.N. 17852

NA-GH4 LCD window for Nauticam enhanced viewfinders

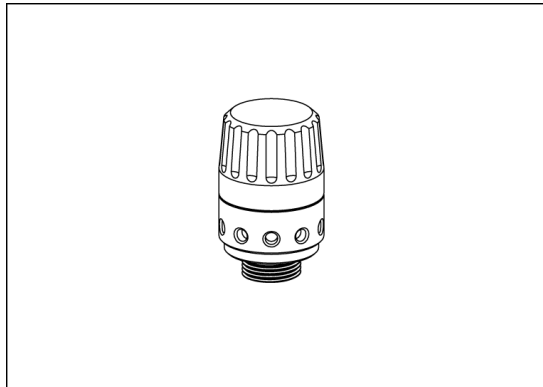

P.N. 25611

M14 Vacuum Valve

NAUTICAM International Limited
Room 2203,
CCT Telecom Building,
11 Wo Shing Street,
Fotan, HONG KONG

Email: enquiry@nauticam.com

Tel: +852 2690 2711

Fax: +852 2690 9778

